

S100 = Schnellläufer  
S200 = Langsamläufer

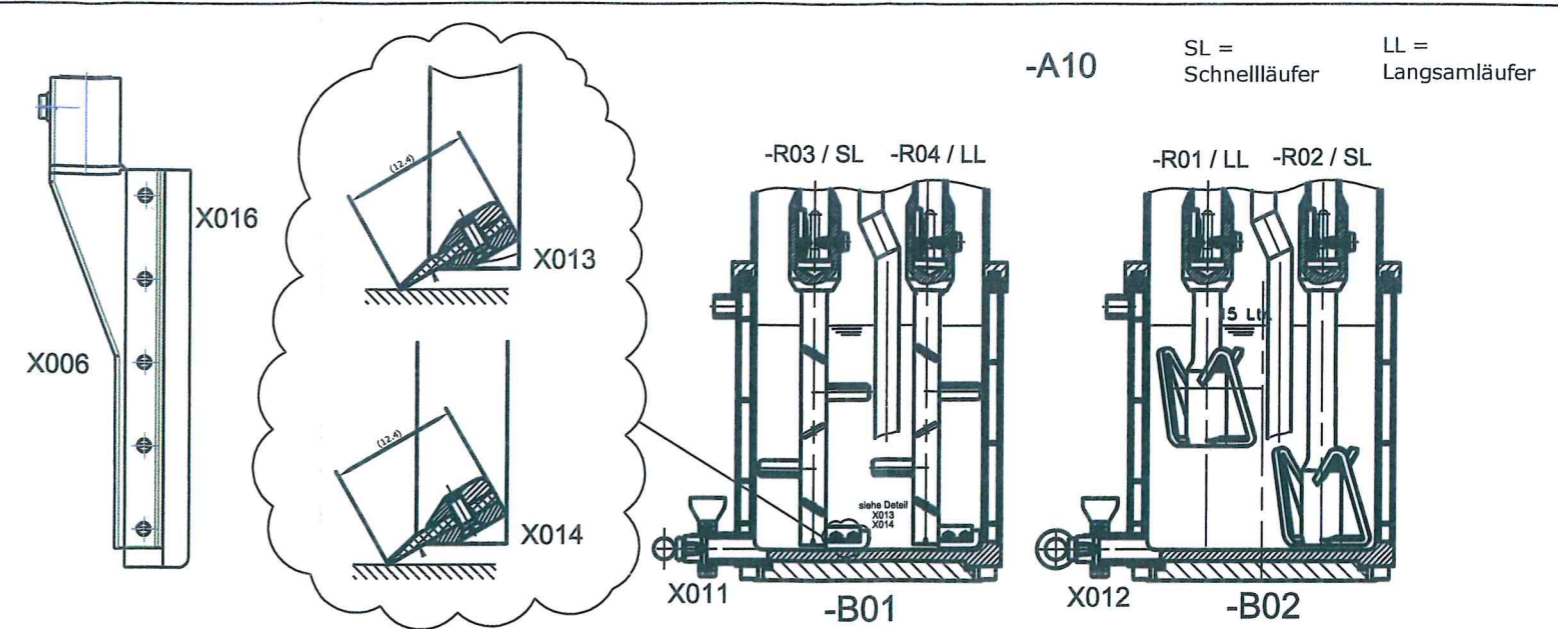

-A10 SL = Schnellläufer LL = Langsamläufer

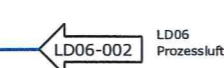
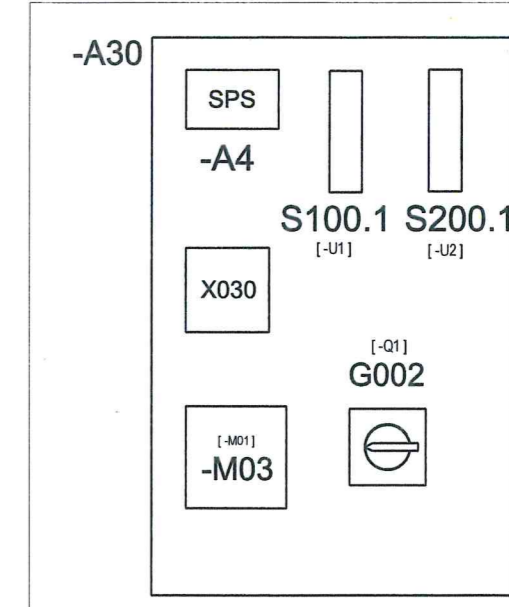
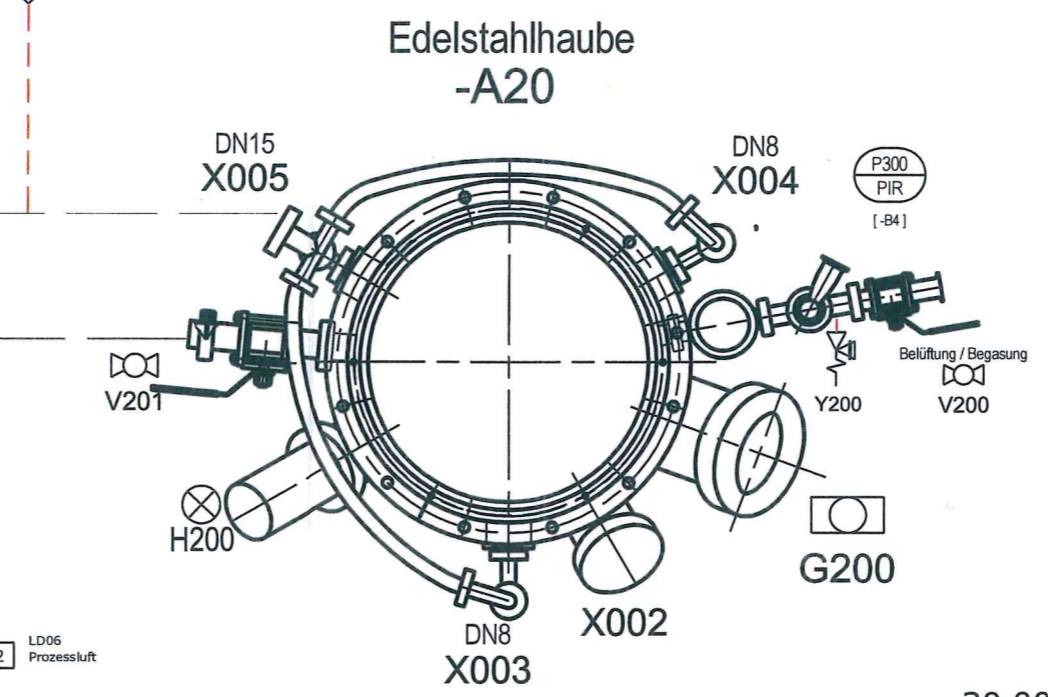
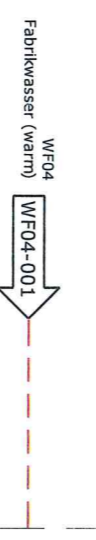

- Messlinie
- Prozessdruckluft
- Vakuum
- Fabrikwasser kalt
- Fabrikwasser warm
- Abwasser

30 00 31  
30 U1 08

**Kopie**

Gewicht der Maschine:  
~1000 kg  
weight of the machine:  
~1000 kgs

1	13.11.13	Mb	"as built" Version
a	13.01.13	Mb	neu gezeichnet
Version	Datum	Kurzzeichen	Bemerkungen
R & I Schema			
Fabrikation			
Mi105 Planetenmischer PMH18 S			
Spig Pharma AG		Massstab: +/-	Zeichnungsnummer
Egerkingen		Zeichn. Herkunft:	S0200
User: Mb		Format: A2	Version: 1
Druckdatum: 13.11.13		Blatt: 1/1	
Pfad: G:\CAD\Anlagen\Fabrikation\Mi105 Planetenmischer\Mi105_Planetenmischer.dwg			